

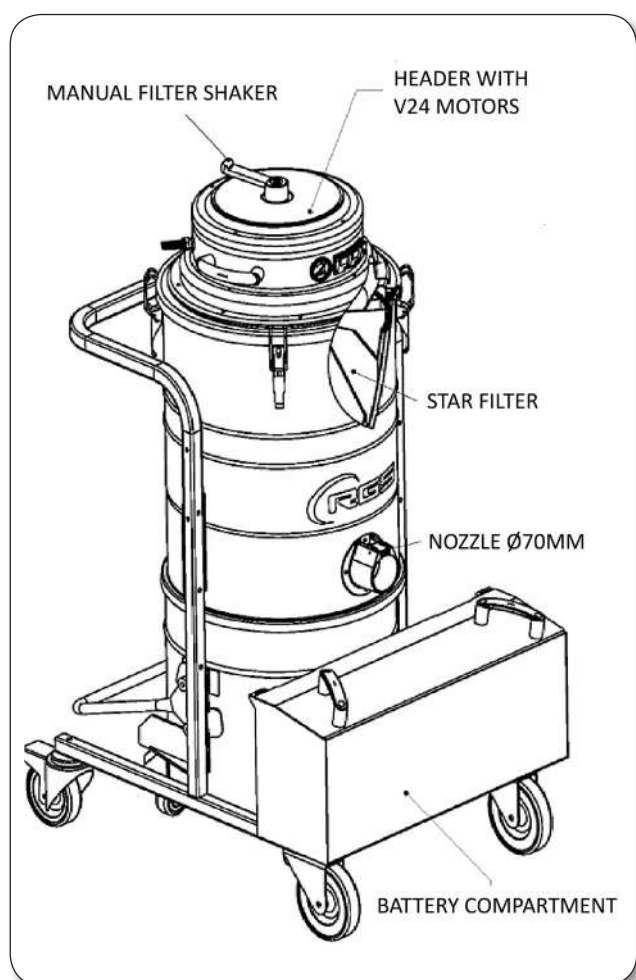

BATTERY INDUSTRIAL VACUUM CLEANER

ONE63ECO24

Industrial vacuum cleaner battery operated, particularly suitable for the cleaning of large spaces thanks to the possibility of use without connection to the mains, hence no constraint due to connecting cables. This machine has a great flexibility of use also possesses flexibility of use, in fact it can be used to clean easily the floor, thanks to the fixed front nozzle, but also as a pure industrial vacuum cleaner, then for the cleaning of machinery, working center, dedusting.



Vacuum cleaner complying with the requirements of the Machinery Directive 2006/42/CE and the Directives 2014/30/EU, 2014/35/EU.

VACUUM CLEANER'S FEATURES

- 24 V direct-current motors
- independent switches for each motors
- gauge for filter clogging indication
- battery compartment for 2 batteries
- Possibility of sucking liquids on the floor
- 460 mm painted steel filter chamber and starry polyester filter class "L"
- Handy external filter shaker.
- Robust chassis made of carbon steel, with special high resistance treatment
- waste paint container in painted steel capacity 65 lt, easily removable thanks to a quick release system
- Quick-action Ø70 socket for easy insertion of accessories, made of aluminum casting
- Battery charge level indicator

ONE63ECO24

RECOMMENDED ACCESSORIES:

- N 1. Galvanized steel fitting \varnothing 50
- Mt. 5 flexible hose \varnothing 50 mm complete with connection sleeves
- N. 1 flat \varnothing 50 \varnothing in pvc
- N. 1 brush Brush \varnothing 100 - Connection \varnothing 50
- N. 1 fixing pad for floor cleaning

TECHNICAL DATA

ONE63ECO24

Voltage	24 V - DC
Power	1,35 kW (450x3) W
Working depression	120 mbar
Max. air flow	420 m ³ /h
Filtering surface	1,9 m ²
Secondary filtering surface (optional)	2,2 m ²
Container capacity	65 lt
Diameter product inlet	70 mm
Sound pressure	70 dB (A)
Maximum size	80x68x138 h (cm.)
Weight with batteries	126 kg
Protection's degree	IP 20



24 V single phase headboard

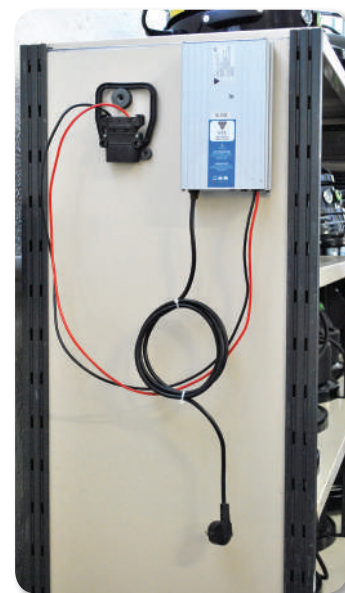

Battery charger



Battery compartment

